

Smart Life App

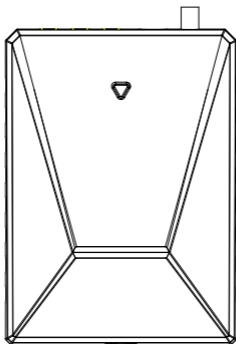

PC341-W-TY

Multi-Circuit Power Meter

Quick Start Guide

Safety Handling

WARNING: Failure to follow these safety notices could result in fire, electric shock, other injuries, or damage to the Power Meter and other property. Read all the safety notices below before using the Power Meter.

- Avoid high humidity or extreme temperatures.
- Avoid long exposure to direct sunlight or strong ultraviolet light.
- Do not drop or expose the unit to intense vibration.
- Do not disassemble or try to repair the unit on your own.
- Do not expose the unit or its accessories to flammable liquids, gases or other explosives.

Technical Specifications

Wireless Connectivity

Wi-Fi	<ul style="list-style-type: none">• 802.11 b/g/n @ 2.4GHz
RF Characteristics	<ul style="list-style-type: none">• Operating frequency: 2.4GHz• External magnetic antenna

Physical Specifications

Operating Voltage	<ul style="list-style-type: none">• 90~380 Vac 50/60 Hz
Supported Systems	<ul style="list-style-type: none">• Single-Phase up to 380VAC line-neutral• Split-Phase 120/240VAC• Three-Phase up to 480Y/277VAC (No Delta/wye/Y/Star Connection)
Calibrated Metering Accuracy	<ul style="list-style-type: none">• $\pm 2\%$
Reporting Cycle	<ul style="list-style-type: none">• Every 15 seconds
Operating environment	<ul style="list-style-type: none">• Temperature: $-20\text{ }^{\circ}\text{C} \sim +55\text{ }^{\circ}\text{C}$• Humidity: $\leq 90\%$ non-condensing
Dimension	<ul style="list-style-type: none">• 111.3(L) x 81.2(W) x 41.4(H) mm

1

Welcome

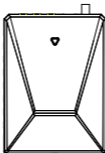

PC341-W-TY Power Meter helps you monitor the amount of electricity Consumed and Production in your facility by connecting the clamp on to the power cable.

This guide will provide you with an overview of the product and help you get through the initial setup to installation.

Features:

- Tuya compliant. Support automation with other Tuya device
- Single, Split-Phase 120/240VAC, 3-Phase/4-wire 480Y/277VAC electricity system compatible
- Remotely monitor whole home Energy and up to 2 individual circuits with 50A Sub CT, like Solar, lighting, receptacles
- Bi-Directional measurement
- Real-time Voltage, Current, PowerFactor, ActivePower, Frequency measurement
- Historical data of Energy Consumed and Energy Production

2

Get to know your device

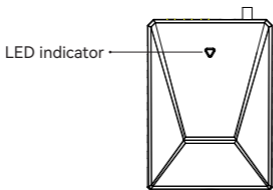

Main Unit



Main CTs
(3.5mm audio plug)



50A Sub CTs
(2.5mm audio plug)



External Antenna



Power cable

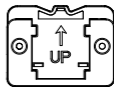

Mounting bracket

All of the ports are labeled on the back of the main unit.

1. The 3.5mm L1/A, L2/B, and L3/C audio ports on the top of the main unit are the inputs for the Main CTs.

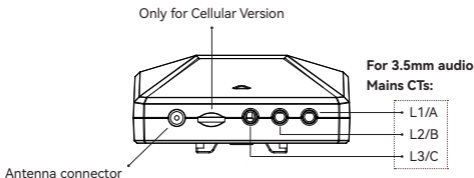

2. The 2.5mm audio ports on the sides of the main unit are the inputs for the Sub CTs

For 2.5mm audio
Circuit CTs:

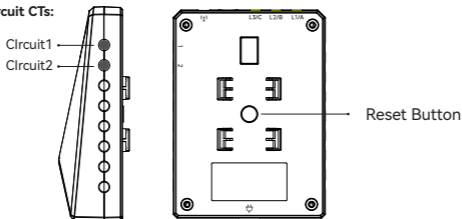

3. The port on the bottom of the main unit are the inputs for power cable

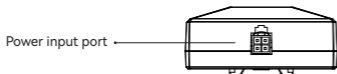

Reset Button

- **Reset.** Press and hold the reset button for 5 seconds until the LED indicator flashes red 3 times quickly to restore the Power Meter to default factory settings (energy data will not be cleared).

If you want to clear the energy data, please delete the device and wipe data on the app and add it again.

LED indicator

The LED status gives the following information of the Power Meter:

LED Status	What it means
Green LED blinking	Wait for pairing
Green LED solid on	Device has connected to cloud.
Red LED solid on	Device is connected to the router, but failed to connect to the cloud.
Red LED blinking	Wi-Fi has been configured, but failed to connect to the router.

3

Installation

Important safety information!

- The Power Meter must be installed and serviced only by a qualified electrical personnel.
- Do not touch the terminals of the device during testing.
- Make sure that the power supply is off before connecting or disconnecting it to an auxiliary device.
- Always use a properly rated voltage sensing device to confirm power is off.
- Replace all devices, doors and covers before applying power to the equipment.

Failure to follow these instructions will result in death or serious injury.

01 Turn off power

You need to turn off the main breaker in your electric panel to shut off all of the power in your home (**However, the service mains are always live!**). Then remove screws securing the cover to the panel to access the circuit breakers.

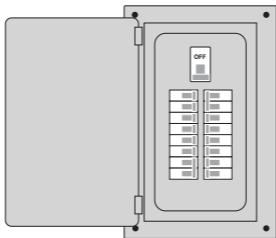

02 Find a spot for Power Meter

Find a spot that works for you. You can fit it within your electrical panel or you can use mounting bracket to fix it on the wall outside the electrical panel if there is no room for your electrical panel.

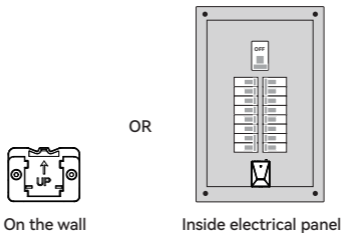

03 Install the antenna

Locate the External Antenna outside the electrical panel to ensure that the Power Meter signal is not blocked by metal (The base of the antenna has a magnetic and can be adsorbed on iron materials). After that, screw the External Antenna to the Antenna connector.

If you install the Power Meter into the electrical panel, you can use a screwdriver to punch out a knockout cover in the electrical panel. Then feed the External Antenna cable through the hole.

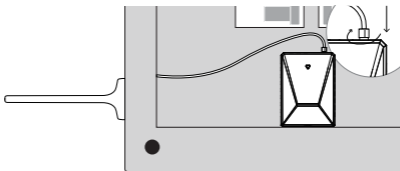

04 Clamp Main CTs around service mains

1. Open the clasps on the Main CTs(3.5mm audio plug) to see the arrow (P1→P2) or (K→L) or you can find it on the sticker on the outside of the clamp. This is the direction of CT.

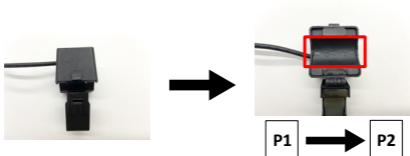

2. Clamp one Main CT on each main service lines. **Make sure the arrow on the CT must point towards the breakers!** Your system may have 1, 2, or 3 main service lines, and a corresponding number of Main CTs are required.

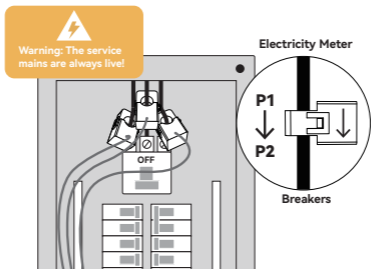

3. If you have Line/Service-side tap solar, Main CT must be clamped between the electricity meter and incoming feeds from inverter.

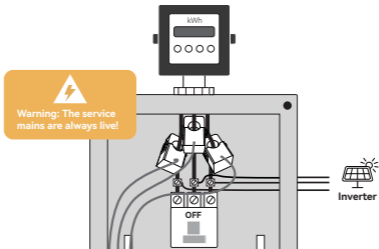

4. Insert each 3.5mm audio plug of Main CT into the corresponding audio jack on the top of the Power Meter:

- The CT measuring the L1/A line should plug into the audio jack labeled L1/A.
- The CT measuring the L2/B line should plug into the audio jack labeled L2/B.
- The CT measuring the L3/C line should plug into the audio jack labeled L3/C.

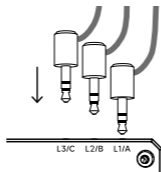

Please refer to the picture below for the number and location of Main CTs in different systems:

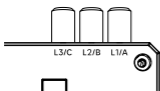

3-Phase

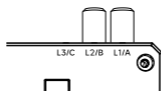

Split-Phase

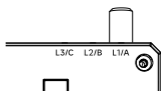

Single Phase

05 Connect the power

1. Connect the power cable into the bottom of the main unit until it clicks into place securely.

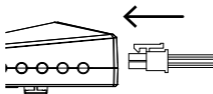

2. Secure N wire from the power cable to the neutral bus bar and L1 wire to the L1/A breaker pole.

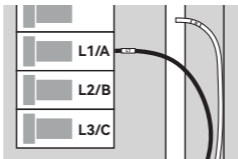

If your system is 3-Phase, secure the L2, L3 wire corresponding to L2/B, L3/C breaker pole.

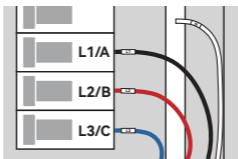

3-Phase

If your system is Split-Phase, only secure the L2 wire to L2/B breaker pole. L3 wire need to connect to the neutral bus bar.

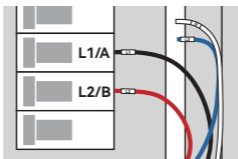

Split-Phase

If your system is Single Phase, the L2 and L3 wire need to connect to the neutral bus bar.

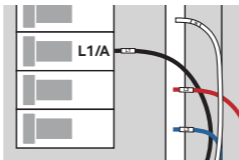

Single Phase

06 Clamp Sub CTs around the circuit

If you don't have Sub CTs(2.5mm audio plug), skip this step.

1. Open the clasps on the Sub CTs to see the arrow (P1→P2) or (K→L) or you can find it on the sticker on the outside of the clamp. This is the direction of CT.

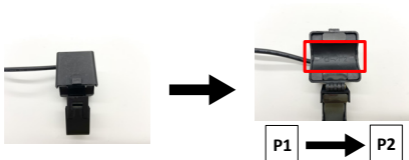

2. Clamp each Sub CTs around the circuit you wish to monitor. **Make sure the arrow on the CT must point towards the load or Inverter!**

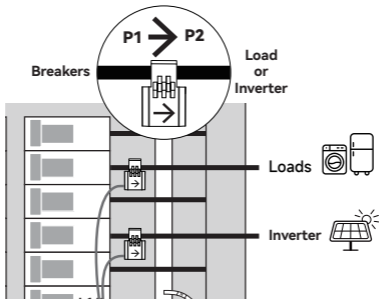

Note: If the circuit you are monitoring can generate energy such as Inverter, etc., after all the wiring is completed, please manually set the phase of the circuit in the app settings, otherwise the power measurement will be incorrect.

3. Insert each 2.5mm audio plug of Sub CT into the audio jack on the side of the Power Meter. Remember the number of the audio jack connected to the circuit you are measuring, and you may need to match it on your app.

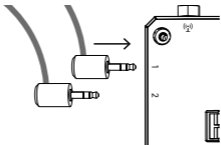

07 Wiring reference

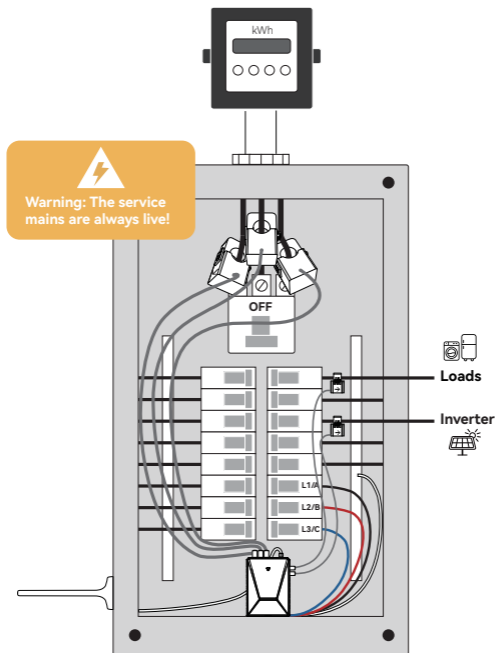

Most in European 3-phase homes and US Commercial systems

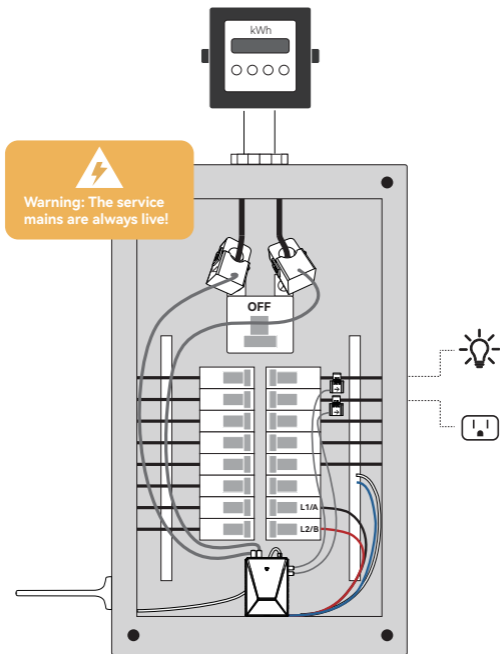

Split-Phase

Most in US homes with Load Monitoring

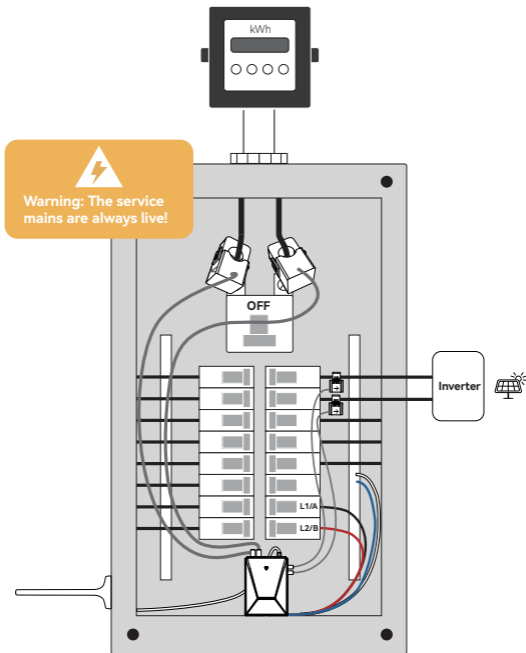

Split-Phase

Most in US homes with Solar Monitoring

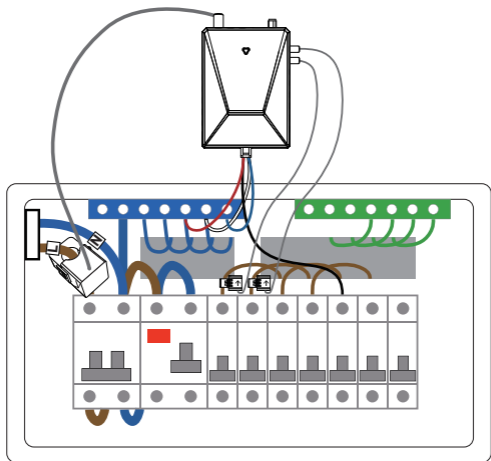

Single Phase

Most in European 1-phase homes

4

Configure Network

Download App

Please download the application: **Smart Life** from App Store or App Market. Also you can scan below QR code to download and install.



Method 1:

1. Open **Smart Life** app and click the 'Scan' button in the upper right corner of the App Home page.

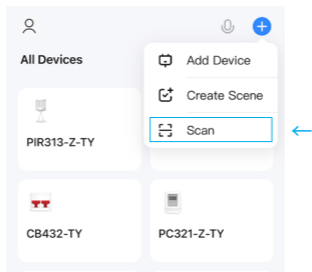

2. Scan the following QR code to configure the network.



Method 2:

1. Power on the power clamp.
2. Make sure the LED indicator is flashing green. If not, please reset it.
3. Open **Smart Life** app and turn on Bluetooth on your phone.



You are advised to enable Bluetooth.

Enable Bluetooth to add some Wi-Fi devices easily.

Allow Bluetooth

Permission

Enabled ✓

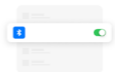

Turn on Bluetooth



4. Open the app and the scanned devices will pop up automatically.

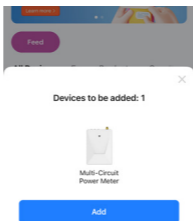

5. If no prompt box pops up automatically, please click the '+' on the top right of the home page to add device. It will search nearby devices.

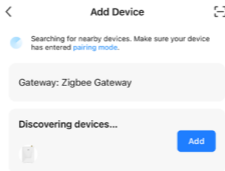

6. After clicking 'Add', enter your home Wi-Fi account and password (**Cannot support 5GHz Wi-Fi!**) and wait for it to be added.

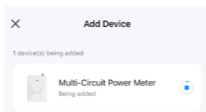

5

Mounting

The mounting bracket supports rail installation, you can click the three hooks on mounting bracket to the Din-Rail.

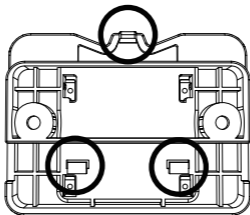

Locate the hooks of the mounting bracket and line up the hooks with the mounting holes on the Power Meter. Fit the hooks into the mounting holes as the picture below. Installation is now completed.

